

bodytone

FORZAHERO



03	Bodytone
06	High quality designs
07	Forza Hero
08	Screen Technology
09	ProductS
27	General highlights
28	Why choose us?

10	FH01 CHEST PRESS
11	FH13 WEIGHT ASSISTED CHIN DIP
12	FH14 LAT PULLDOWN
13	FH15 SEATED ROW
14	FH20 SHOULDER PRESS
15	FH23 PEC FLY / REAR DELT
16	FH24 LATERAL RAISE
17	FH30 BICEPS
18	FH32 CHEST AND TRICEPS

19	FH40 ABDOMINAL / BACK EXT
20	FH50 SQUAT AND CALF
21	FH52 LEG EXTENSION
22	FH53 SEATED LEG CURL
23	FH55 PRONE LEG CURL
24	FH56 INNER OUTER
25	FH58 MULTIHIP
26	FH59 LEG PRESS



**Move.
Live.
Enjoy.**

I'M A RUNNER



Our passion for sport helps us see things from our customers' point of view. Since the creation of Bodytone, we have worked hand in hand with fitness professionals, listening to their needs and creating products and solutions that improve their sports centers, the experience of their clients and the profitability of their business.

Bodytone equips both large gym chains and independent centers, responding reliably to the highest levels of demand. Likewise, hotels, residential complexes, universities, corporate spaces and clinics trust us.

We design technologically advanced and connected products that are interactive and can track workouts to take the home gym experience to the next level.

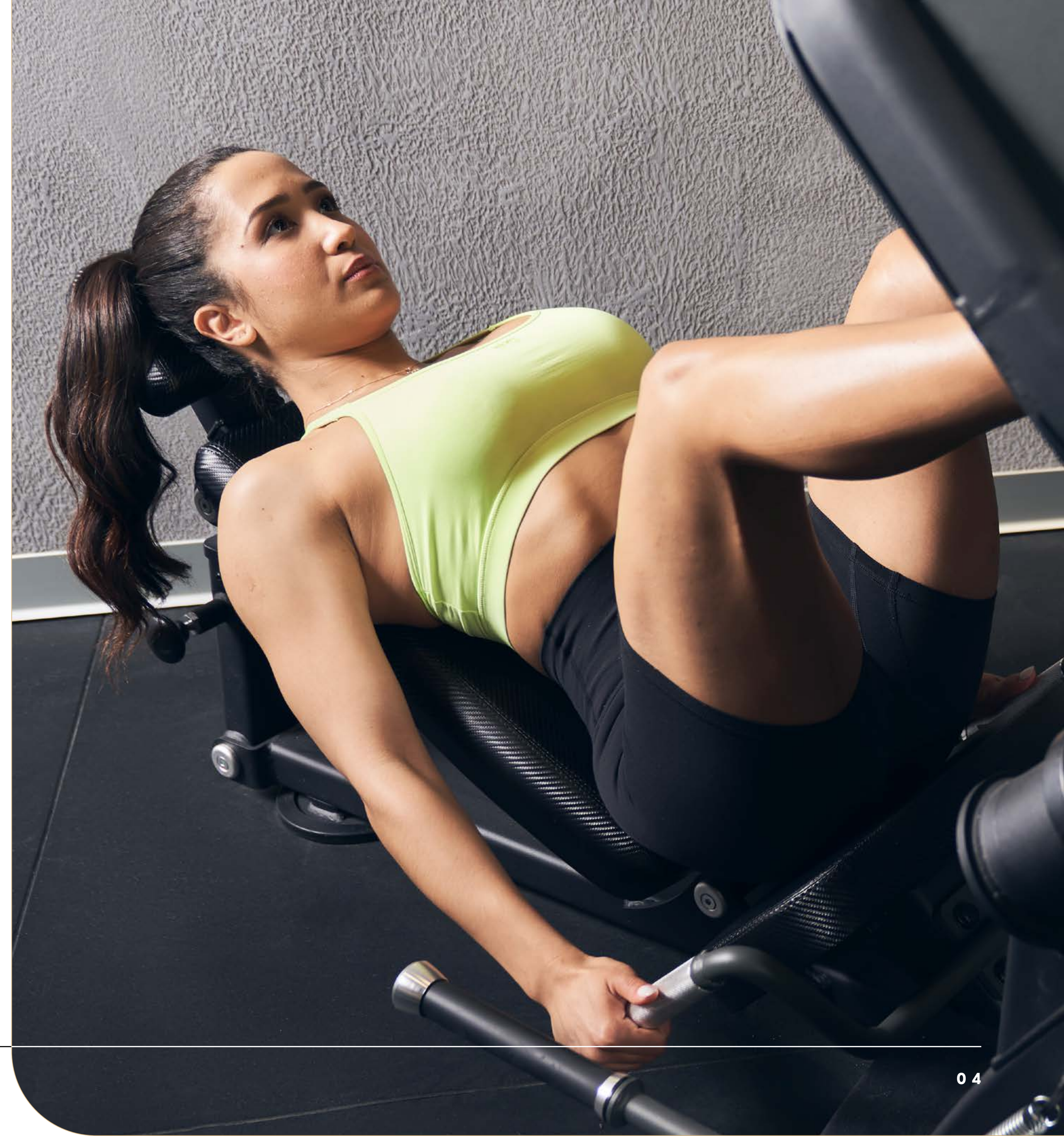

The key to Bodytone is to help professionals boost their business:



**TAILOR-MADE
FINANCING**



**CUSTOMER SERVICE AND
UNIQUE GUARANTEES**



**PROFITABILITY FOR
THEIR BUSINESS**



CREATIVE PROCESS: **HIGH QUALITY DESIGNS**

Bodytone's design team works every day to create world-class equipment through a successful formula that integrates research centres, professionals and users.

Bodytone has collaboration agreements with relevant research centers around sports and biomechanics from prestigious universities such as the University of Valencia or the Catholic University of Murcia in order to take its products to a higher level in order to provide the maximum experience to the users.



FORZAHERO

This new line is a selection of Bodytone's premium strenght machines, focusing in the user for an excelent training results. Discover all >>>



Digital counter



Connectivity pack screen 9" and NFC (optional)



Bottle and mobile holder



High quality termoplastic covers

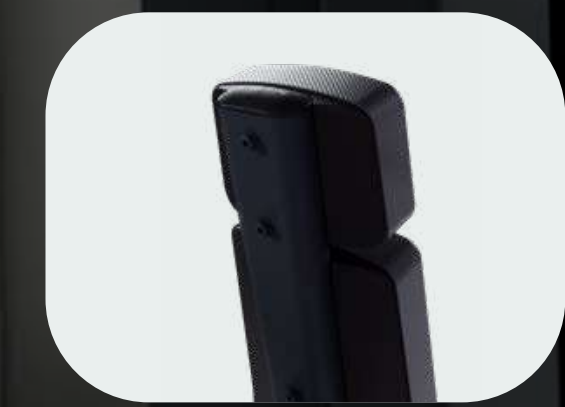

Upholstery ABS covers



Carbon fiber finish



Non-slip PVC grips with aluminium caps



Ultrasilent bearings

SCREENTECHNOLOGY

IMPROVE THE PRECISION
OF YOUR WORKOUTS

MONITORIZE
YOUR TRAINING

INTERACTIVITY
AT THE TIME



CONNECTED TO
YOUR CENTER'S APP
powered by

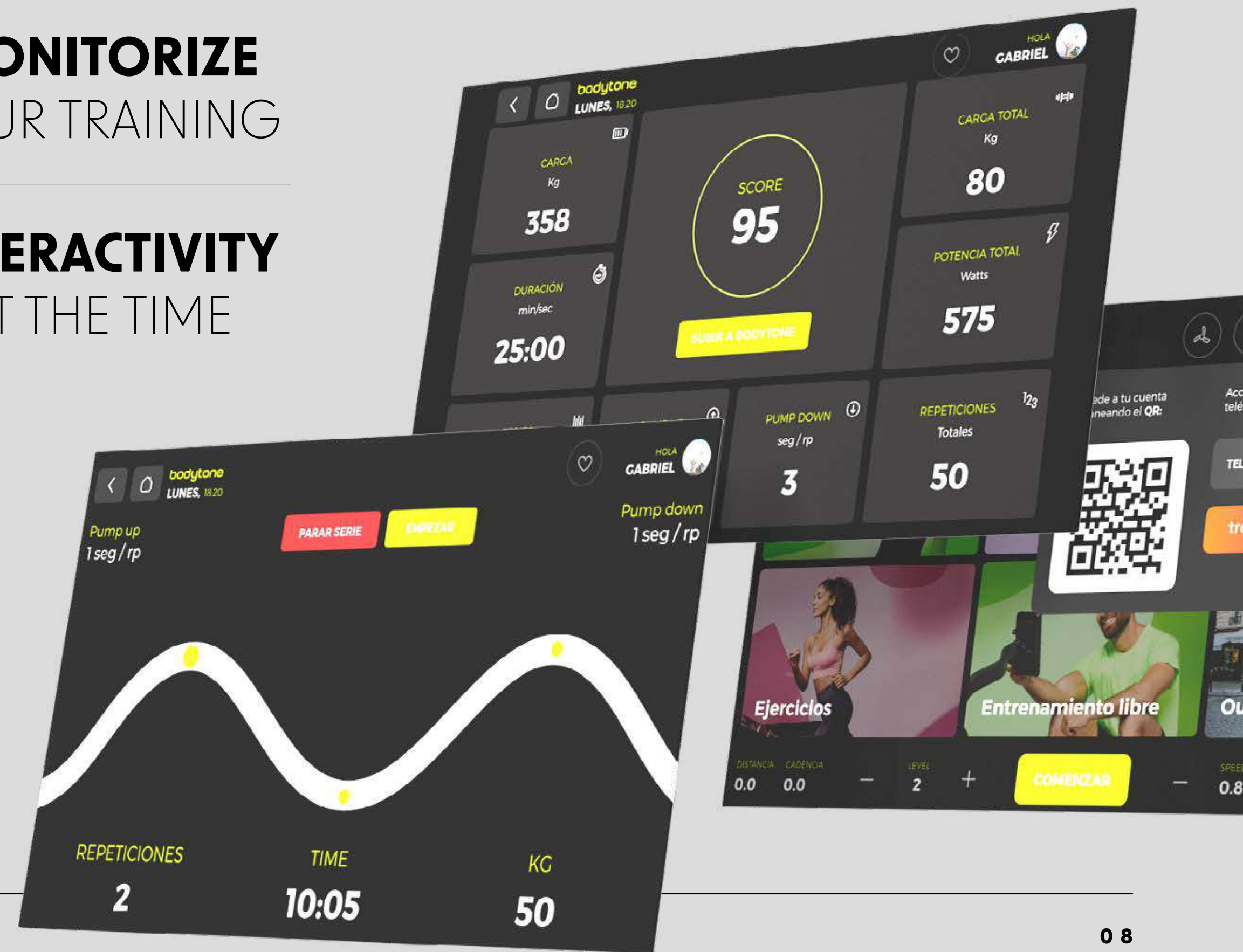
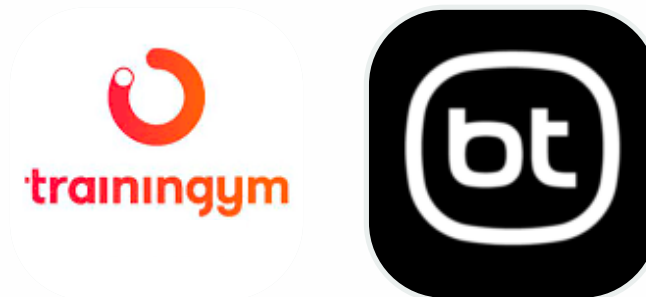

FORZA HERO PRODUCT MAP

CHEST



FH01
CHEST PRESS



FH23
PEC FLY / REAR DELT



FH13
ASSISTED CHIN DIP



FH14
PULLDOWN



FH15
SEATED ROW

SHOULDER



FH20
SHOULDER PRESS



FH24
LATERAL RAISE



FH30
BICEPS



FH32
SEATED DIP



FH40
AB CRUNCH



FH50
SQUAT AND CALF



FH52
LEG EXTENSIONS



FH53
SEATED LEG CURL



FH55
PRONE LEG CURL



FH56
ABDUCTION / INNER



FH58
MULTIHIP



FH59
LEG PRESS

BACK

ARMS

ABDOMEN

LEG



FH01 CHEST PRESS

EXERCISE

Horizontal chest press machine with assistance lever for the exercise and isolateral independent movement.

DIMENSIONS

151 x 120 x 165 cm

WEIGHT

163 kg

WEIGHT PLATES

107 kg (7 kg/plate)

PRODUCT HIGHLIGHTS

- 1 Foam seat upholstered in imitation leather with rear protective cover in injected ABS.
- 2 Assistance lever to perform the exercise.
- 3 Non-absorbent non-slip PVC grips. Ergonomic shape adapted to the exercise of the machine.
- 4 Connectivity kit with 9" screen and NFC (optional)

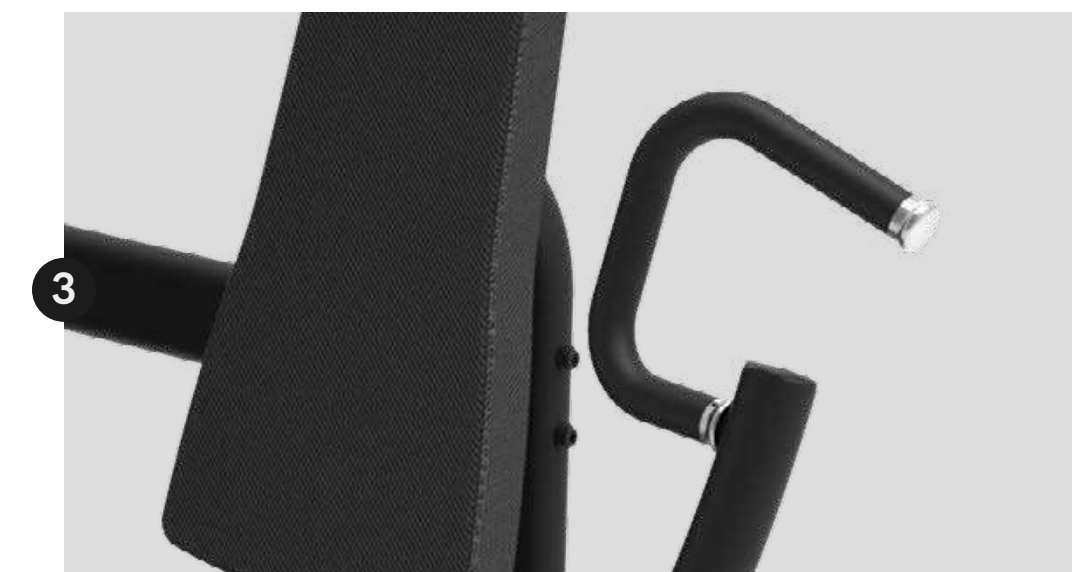



FH13

WEIGHT ASSISTED CHIN DIPS

EXERCISE

Machine to do lats with wide or narrow grip with the help of weight. Dips and triceps can also be performed.

DIMENSIONS

1421 x 161 x 229 cm

WEIGHT

183 kg

WEIGHT PLATES

107 kg (7 kg/plate)

PRODUCT HIGHLIGHTS

- 1 Foam seat upholstered in imitation leather.
- 2 Non-slip individual entry platforms and exit from the exercise.
- 3 Non-absorbent non-slip PVC grips. Ergonomic shape adapted to the exercise of the machine.
- 4 Connectivity kit with 9" screen and NFC (optional)





FH14 LAT PULLDOWN

EXERCICE

Machine to do pull downs in front of the back with open or closed grip. It favors the development and breadth of the latissimus dorsi.

DIMENSIONS

142 x 137 x 195 cm

WEIGHT

172 kg

WEIGHT PLATES

107 kg (7 kg/plate)

PRODUCT HIGHLIGHTS

- 1 Foam seat and rollers upholstered in imitation leather.
- 2 Ultra-silent bearings.
- 3 Non-absorbent non-slip PVC grips. Ergonomic shape adapted to the exercise of the machine.
- 4 Connectivity kit with 9" screen and NFC (optional)

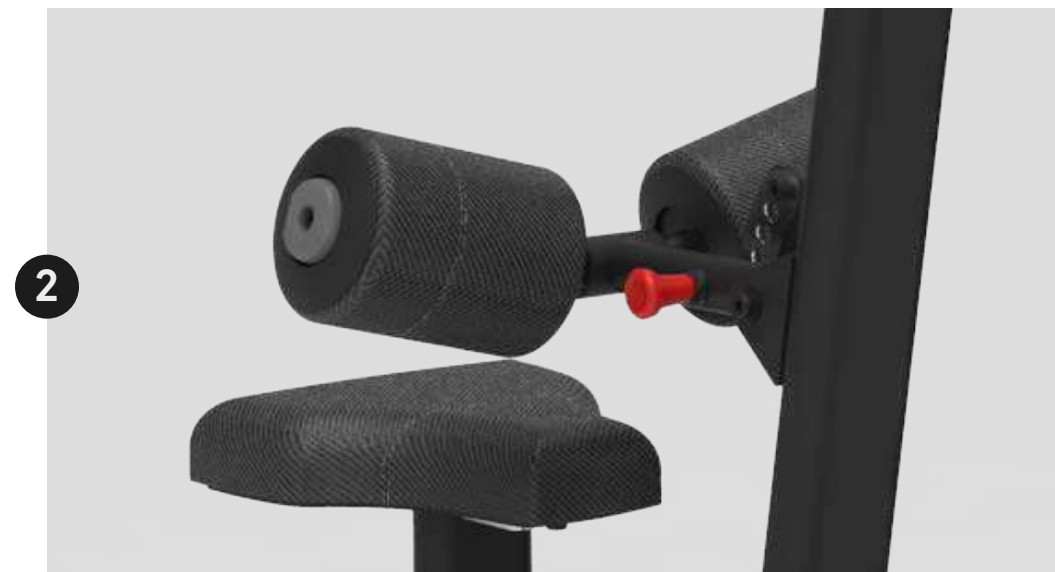



FH15 SEATED ROW

EXERCICE

Seated rowing machine. It works the muscles of the upper part of the back and also the latissimus dorsi. This exercise helps to improve posture.

DIMENSIONS

130 x 161 x 162 cm

WEIGHT

159 kg

WEIGHT PLATES

107 kg (7 kg/plate)

PRODUCT HIGHLIGHTS

- 1 Foam seat upholstered in imitation leather.
- 2 Assistance lever to perform the exercise.
- 3 Non-absorbent non-slip PVC grips. Ergonomic shape adapted to the exercise of the machine.
- 4 Connectivity kit with 9" screen and NFC (optional)

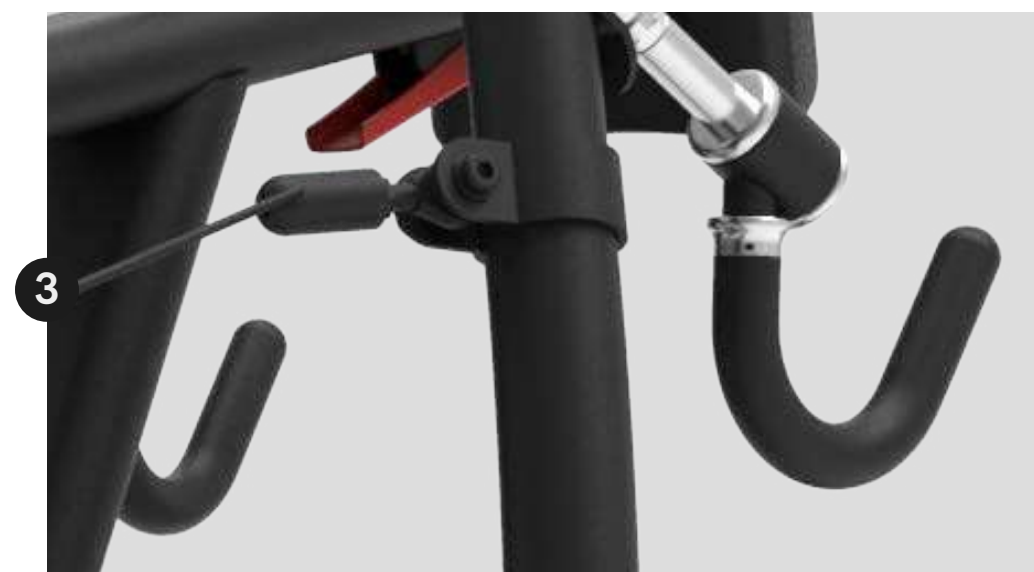



FH20

SHOULDER PRESS

EXERCICE

Shoulder press machine. Works the deltoid, rhomboid, and upper pectoral muscles.

DIMENSIONS

155 x 149 x 162 cm

WEIGHT

152 kg

WEIGHT PLATES

107 kg (7 kg/plate)

PRODUCT HIGHLIGHTS

- 1 Foam seat upholstered in imitation leather with rear protective cover in injected ABS.
- 2 Ultra-silent bearings.
- 3 Non-absorbent non-slip PVC grips. Ergonomic shape adapted to the exercise of the machine.
- 4 Connectivity kit with 9" screen and NFC (optional)





FH23

PEC FLY / REAR DELT

EXERCICE

Machine to open the chest and back of the shoulder. Its double grip facilitates diversity in the angles of the exercise.

DIMENSIONS

130 x 150 x 205 cm

WEIGHT

141 kg

WEIGHT PLATES

107 kg (7 kg/plate)

PRODUCT HIGHLIGHTS

- 1 Foam seat upholstered in imitation leather.
- 2 Double position of the machine for the exercise.
- 3 Non-absorbent non-slip PVC grips. Ergonomic shape adapted to the exercise of the machine.
- 4 Connectivity kit with 9" screen and NFC (optional)





FH24

LATERAL RAISE

EXERCICE

Machine to do lateral shoulder raises, for a slow and controlled execution of the exercise.

DIMENSIONS

123 x 109 x 162 cm

WEIGHT

127 kg

WEIGHT PLATES

91 kg (7 kg/plate)

PRODUCT HIGHLIGHTS

- 1 Foam seat upholstered in imitation leather.
- 2 Ultra-silent bearings.
- 3 Non-absorbent non-slip PVC grips. Ergonomic shape adapted to the exercise of the machine.
- 4 Connectivity kit with 9" screen and NFC (optional)





FH30 BICEPS

EXERCICE

Machine to make biceps curls with arms support for a better development of the exercise.

DIMENSIONS

123 x 124 x 162 cm

WEIGHT

150 kg

WEIGHT PLATES

91 kg (7 kg/plate)

PRODUCT HIGHLIGHTS

- 1 Foam seat upholstered in imitation foot.
- 2 Multi-position adjustment.
- 3 Non-absorbent non-slip PVC grips. Ergonomic shape adapted to the exercise of the machine.
- 4 Connectivity kit with 9" screen and NFC (optional)





FH32

CHEST AND TRICEPS

EXERCICE

Machine for the realization of chest dips with open grip and triceps with closed grip, both seated.

DIMENSIONS

129 x 143 x 162 cm

WEIGHT

150 kg

WEIGHT PLATES

107 kg (7 kg/plate)

PRODUCT HIGHLIGHTS

- 1 Foam seat upholstered in imitation leather with rear protective cover in injected ABS.
- 2 Ergonomic inclination for exercise adjustment.
- 3 Non-absorbent non-slip PVC grips. Ergonomic shape adapted to the exercise of the machine.
- 4 Connectivity kit with 9" screen and NFC (optional)

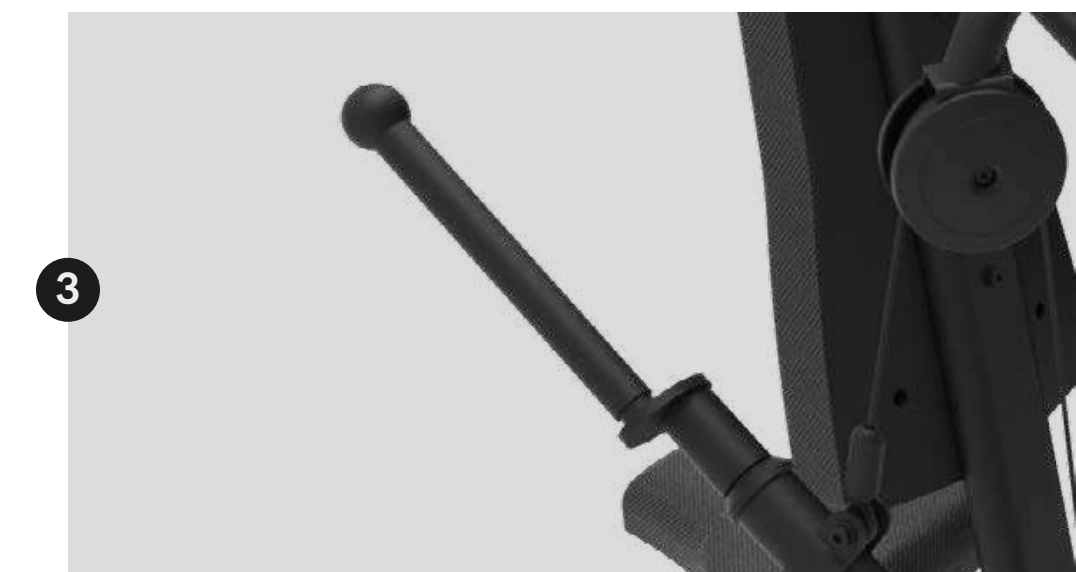



FH40

ABDOMINAL /BACK EXT

EXERCICE

Machine for performing seated crunch abdominals and lumbar extension of the back.

DIMENSIONS

126 x 111 x 162 cm

WEIGHT

140 kg

WEIGHT PLATES

107 kg (7 kg/plate)

PRODUCT HIGHLIGHTS

- 1 Foam seat upholstered in imitation leather.
- 2 Entry assist footrest and exit from the exercise.
- 3 Non-absorbent non-slip PVC grips. Ergonomic shape adapted to the exercise of the machine.
- 4 Connectivity kit with 9" screen and NFC (optional)

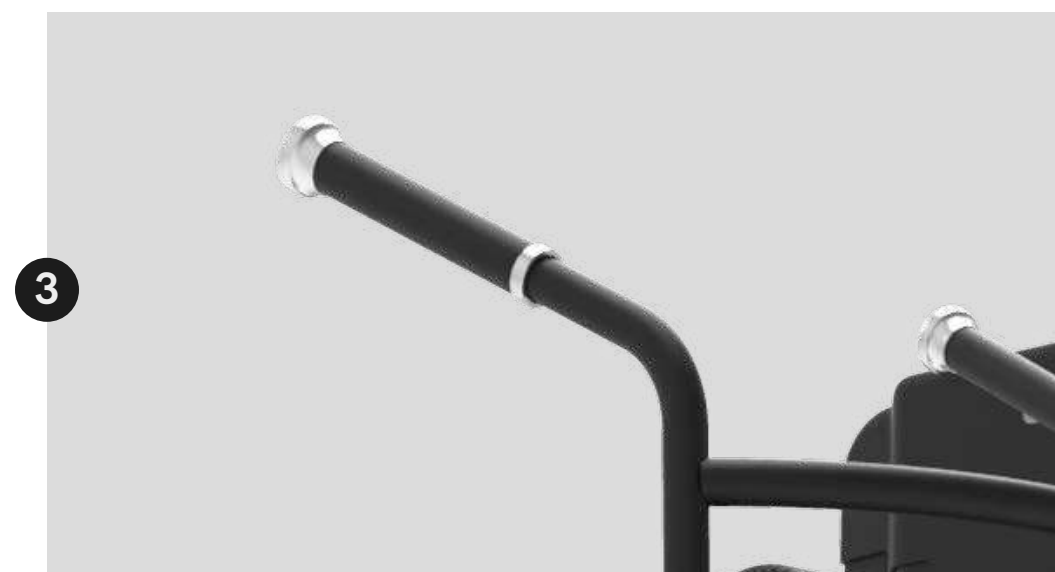



FH50

SQUAT AND CALF

EXERCICE

Squat and calf machine, adapted for a slow and controlled execution of the exercise.

DIMENSIONS

119 x 119 x 175 cm

WEIGHT

131 kg

WEIGHT PLATES

107 kg (7 kg/plate)

PRODUCT HIGHLIGHTS

- 1 Foam shoulder pads upholstered in imitation leather.
- 2 Non-slip platform.
- 3 Non-absorbent non-slip PVC grips. Ergonomic shape adapted to the exercise of the machine.
- 4 Connectivity kit with 9" screen and NFC (optional)





FH52

LEG EXTENSION

EXERCISE

Machine to do quadriceps extensions, being the only exercise that completely isolates it.

DIMENSIONS

135 x 132 x 162 cm

WEIGHT

180 kg

WEIGHT PLATES

107 kg (7 kg/plate)

PRODUCT HIGHLIGHTS

- 1 Foam seat upholstered in imitation leather with rear protective cover in injected ABS.
- 2 Multi-position adjustment.
- 3 Non-absorbent non-slip PVC grips. Ergonomic shape adapted to the exercise of the machine.
- 4 Connectivity kit with 9" screen and NFC (optional)

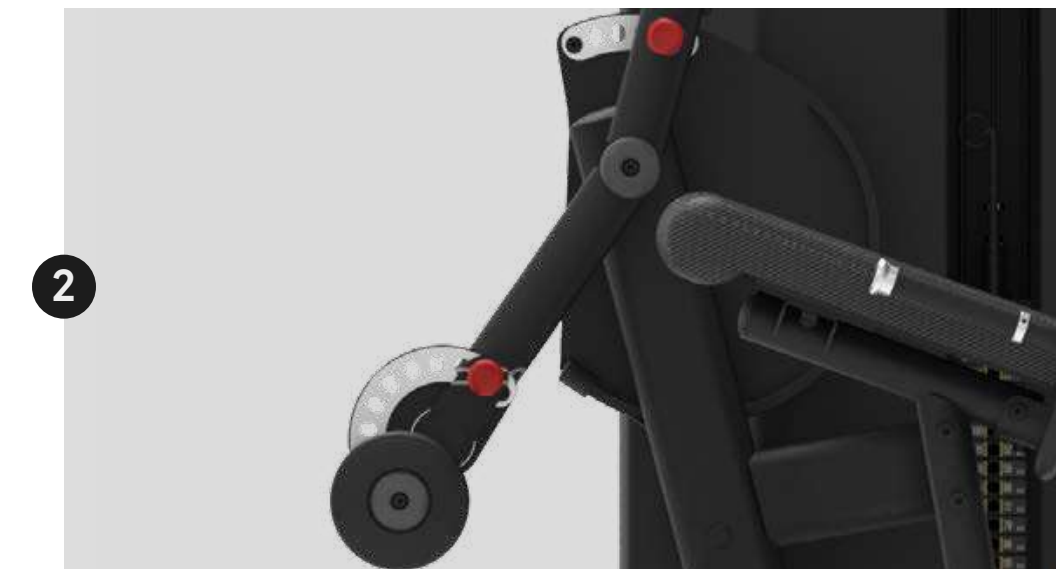



FH53

SEATED LEG CURL

EXERCICE

Seated hamstring curl machine, isolating the semitendinosus and semimembranosus biceps femoris.

DIMENSIONS

126x 149 x 162 cm

WEIGHT

162 kg

WEIGHT PLATES

107 kg (7 kg/plate)

PRODUCT HIGHLIGHTS

- 1 Foam seat upholstered in imitation leather with rear protective cover in injected ABS.
- 2 Multi-position adjustment.
- 3 Non-absorbent non-slip PVC grips. Ergonomic shape adapted to the exercise of the machine.
- 4 Connectivity kit with 9" screen and NFC (optional)





FH55

PRONE LEG CURL

EXERCICE

Lying hamstring curl machine, isolating semitendinosus and semimembranosus biceps femoris.

DIMENSIONS

118 x 144 x 162 cm

WEIGHT

139 kg

WEIGHT PLATES

107 kg (7 kg/plate)

PRODUCT HIGHLIGHTS

- 1 Foam seat upholstered in imitation leather.
- 2 Multi-position adjustment.
- 3 Non-absorbent non-slip PVC grips. Ergonomic shape adapted to the exercise of the machine.
- 4 Connectivity kit with 9" screen and NFC (optional)

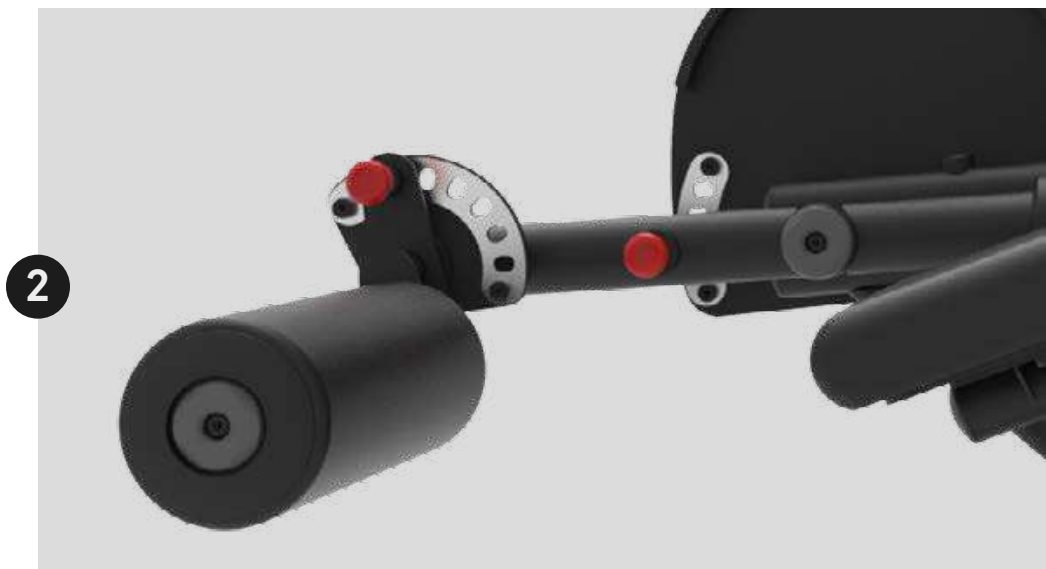



FH56

INNER OUTER

EXERCICE

Machine for performing hip abduction and adduction, separating or approximating the legs with resistance.

DIMENSIONS

163 x 78 x 162 cm

WEIGHT

145 kg

WEIGHT PLATES

91 kg (7 kg/plate)

PRODUCT HIGHLIGHTS

- 1 Foam seat upholstered in imitation leather with rear protective cover in injected ABS.
- 2 Multi-position adjustment.
- 3 Non-absorbent non-slip PVC grips. Ergonomic shape adapted to the exercise of the machine.
- 4 Connectivity kit with 9" screen and NFC (optional)





FH58 MULTIHIP

EXERCICE

Machine to train the flexion, extension, adduction and abduction of the hip.

DIMENSIONS

137 x 97 x 162 cm

WEIGHT

178 kg

WEIGHT PLATES

91 kg (7 kg/plate)

PRODUCT HIGHLIGHTS

- 1 Non-slip platform.
- 2 Multi-position adjustment.
- 3 Support bar to perform the exercise.
- 4 Connectivity kit with 9" screen and NFC (optional)

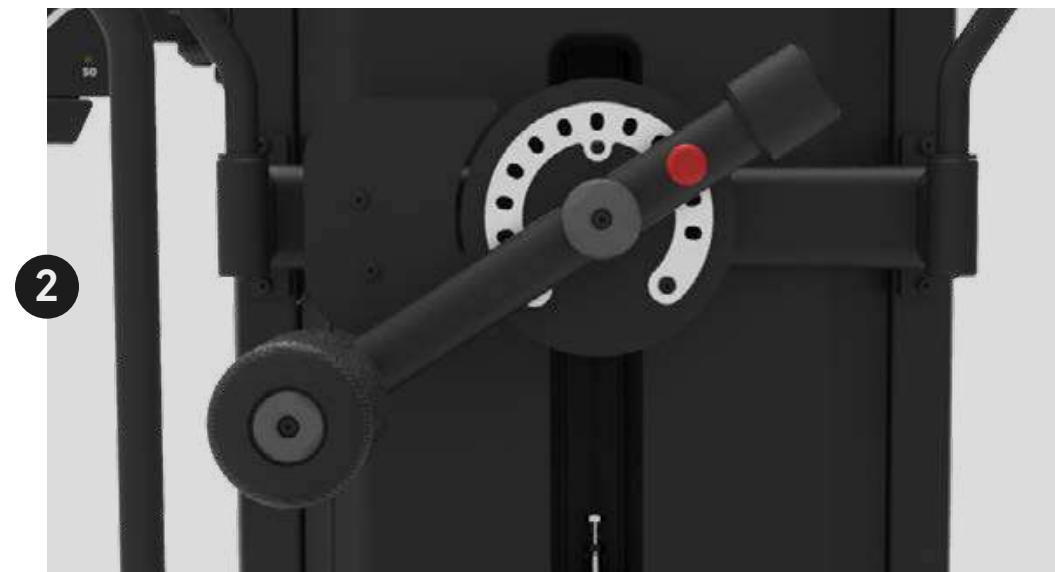
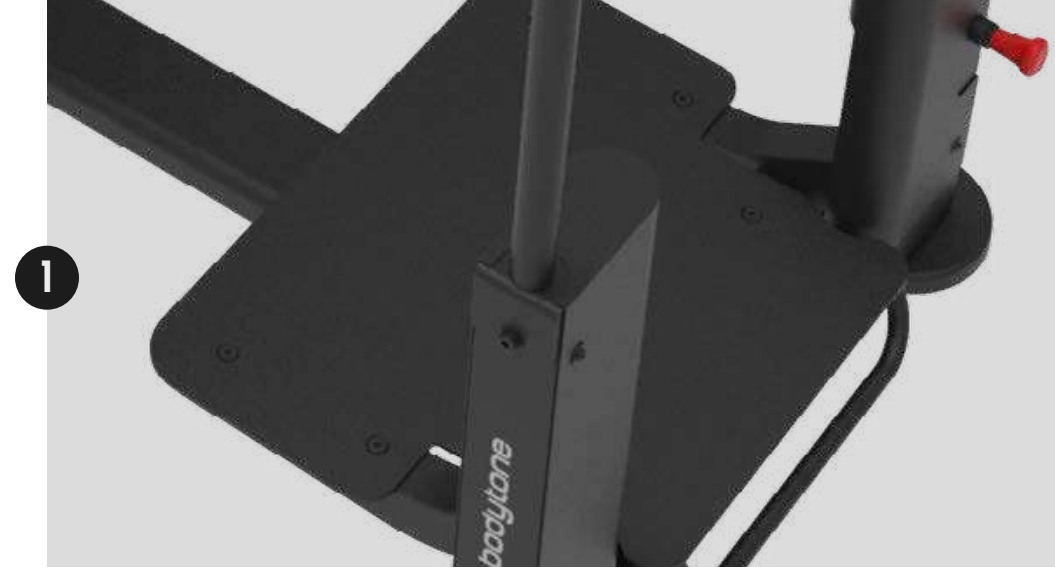



FH59 LEG PRESS

EXERCICE

Machine for exercising the quadriceps, buttocks, and hamstrings on the back of the thighs.

DIMENSIONS

181 x 117 x 165 cm

WEIGHT

240 kg

WEIGHT PLATES

184 kg (7 kg/plate)

PRODUCT HIGHLIGHTS

- 1 Foam seat upholstered in imitation leather with rear protective cover in injected ABS.
- 2 Non-slip platform.
- 3 Non-absorbent non-slip PVC grips. Ergonomic shape adapted to the exercise of the machine.
- 4 Connectivity kit with 9" screen and NFC (optional)





CHARACTERISTICS GENERALS OF THE LINE

STRUCTURE

Plate structure part: 140 x 75 mm carbon steel tube.
Functional part: oval carbon steel tube
of 100 x 50 mm and round tube of 60mm diameter.
Welded by robotic process,
projection free.

BEARINGS

Ultra-quiet ball bearings with smooth sliding, allowing
smooth travel of the exercise more fluent and
pleasant. Measures 52 x 15 mm.

PULLEYS

V-groove nylon. With an internal bearing and quiet
operation.
Step diameter: 95 mm

PLATE GUIDES

Stainless steel plate guides.
Hardened double chrome treatment for better sliding.

STEEL WIRES

PVC coated and 5mm in diameter, with smooth and
safe performance. Breakage index test: 1,000kg.
Safety terminal with steel ball joints.

WEIGHT PLATES

107 kg as standard, with 7 kg plates.
Ultra-quiet movement. protective stops
rubber on anti-knock base. protective stops
of PVC between anti-knock plates.

WEIGHT SELECTOR

Magnetic, color-coded plates by intensity level, and
safety lanyard.

ADJUSTMENT LEVERS

In aluminum, quick release, in red to facilitate its
location.

PLATE FAIRING

3mm thick thermoformed ABS fairing, to protect from
possible accidents.

BOTTLE RACK AND UPPER STORAGE

3mm thick thermoplastic ABS piece. Includes bottle
rack and slide tray with non-slip texture.

REPEATCOUNT

As standard, integrated into the fairing.

GRIPS

Non-absorbent non-slip PVC.

HANDLE STOP

Aluminum cuff stops and trims.

BACKS AND UPHOLSTERY

Back, headrest and seat made of foam, upholstered
in imitation leather, anti-allergic and easy to clean,
with a carbon fiber effect texture.

BACKREST COVERS

Rear protector cover made of injected ABS.
Protects and reinforces upholstery on the back.

TOWEL FIXING SYSTEM

Located at the rear of the head. Metallic with
elastic rubber for easy hooking to the towel,
favoring the fastening to the backrest.

MATERIALS AND FINISHES

High quality in its finishes.
3.5mm thermoplastic ABS ferrules.

BASES

Covered in non-slip rubber.

ARMS MOVEMENT

Isolateral independent movement.

MAINTENANCE AND LUBRICATION

Lubrication of bearings and calibrated steel
guides.

PAINTING PROCESS

3 coats of paint. Pickled and stabilized steel
by total immersion of the parts in different
degreasing solutions to guarantee a perfect
and complete cleaning of the base material.
Anti-rust primer to ensure proper isolation of
internal oxidation and good paint adhesion.
In addition, it has 2 final layers of epoxy
polyester powder paint dried at 240°C.

DESIGN PROCESS

Study of biomechanics and ergonomics under
the supervision of associated professionals
and athletes. After a long design period; From
the sketch, engineering research, prototyping
and testing by professional athletes, our
products go to market.

WHY CHOOSE US?

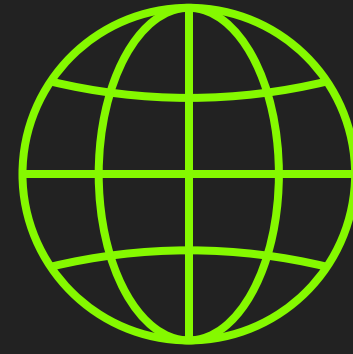

WE UNDERSTAND THE MARKET

We have a track record of more than 20 years in the fitness sector and are present in 40 countries across 5 continents.



WE HAVE A TEAM OF SPECIALISTS AT YOUR DISPOSAL

At Bodytone, you'll always deal with professionals who can help you find the perfect solutions to your needs. We're committed to quality service to guarantee your complete peace of mind.

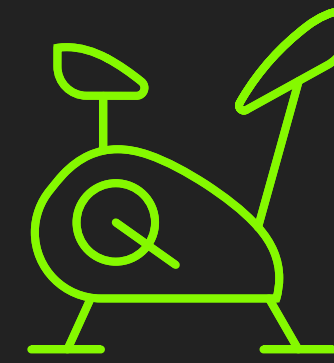

WE OFFER THE HIGHEST QUALITY

From the initial idea, through to the creation of the product and its final processing, we work to ensure our products exceed expectations.



WE'RE HERE TO HELP

We support our customers throughout the installation and after-sales process to provide them with all the assistance and advice they need.

TRUST
IN US:



